



Application for footpath alterations on a public road

Section 221 of the Local Government Act 1999, provides Council the ability to control works on roads, including requiring property owners, builders and developers to obtain permission from Council to do works (construction, replacement or removal) on the footpath outside their property.

A footpath represents a shared path for pedestrians and cyclists to travel along within the verge or on council land. No fee is required for a footpath alteration application.

**Written approval is to be given from Council, prior to the commencement of works on site.
Please allow at least 10 working days to assess applications.**

APPLICANT DETAILS

Are you the property owner?

Yes No

No – but I have attached formal permission from the property owner to submit the application.

If no, are you a part of a Community Title?

Yes – and I have attached formal permission from the property owners to submit the application.

No

Full name:

Phone number:

Email address:

Residential address:

Postal address (if
different to above):

Work Site details

Site address:

Proposed timings of works:

Start date:

Completion date:

Does this application relate to a Development Application? Yes No

If yes, please provide Development Application Number:

Contractor details

Full name:	
Mobile number (Site contact number):	
Email address:	
ABN:	
Office address:	

DETAILS OF WORK

Existing footpath surface:

- Concrete Pavers Hot mix asphalt Unmade
 Other _____

Proposed footpath works:

- Changing footpath material

New material:

- Plain Concrete Pavers Hot mix asphalt Unmade Other _____

- Widening footpath New width: mm

- Extending footpath length Additional length: m

- Installing new footpath Length of footpath: m Width of footpath: mm

- Replacing footpath with the same material

- Other _____

Note: Council does not permit the construction of exposed aggregate concrete footpath

Other information

Please provide further details and a sketch of the proposed works that includes dimensions, boundaries, materials, kerb, trees, stobie poles, driveways and stormwater infrastructure, north arrow, property numbers and street names.

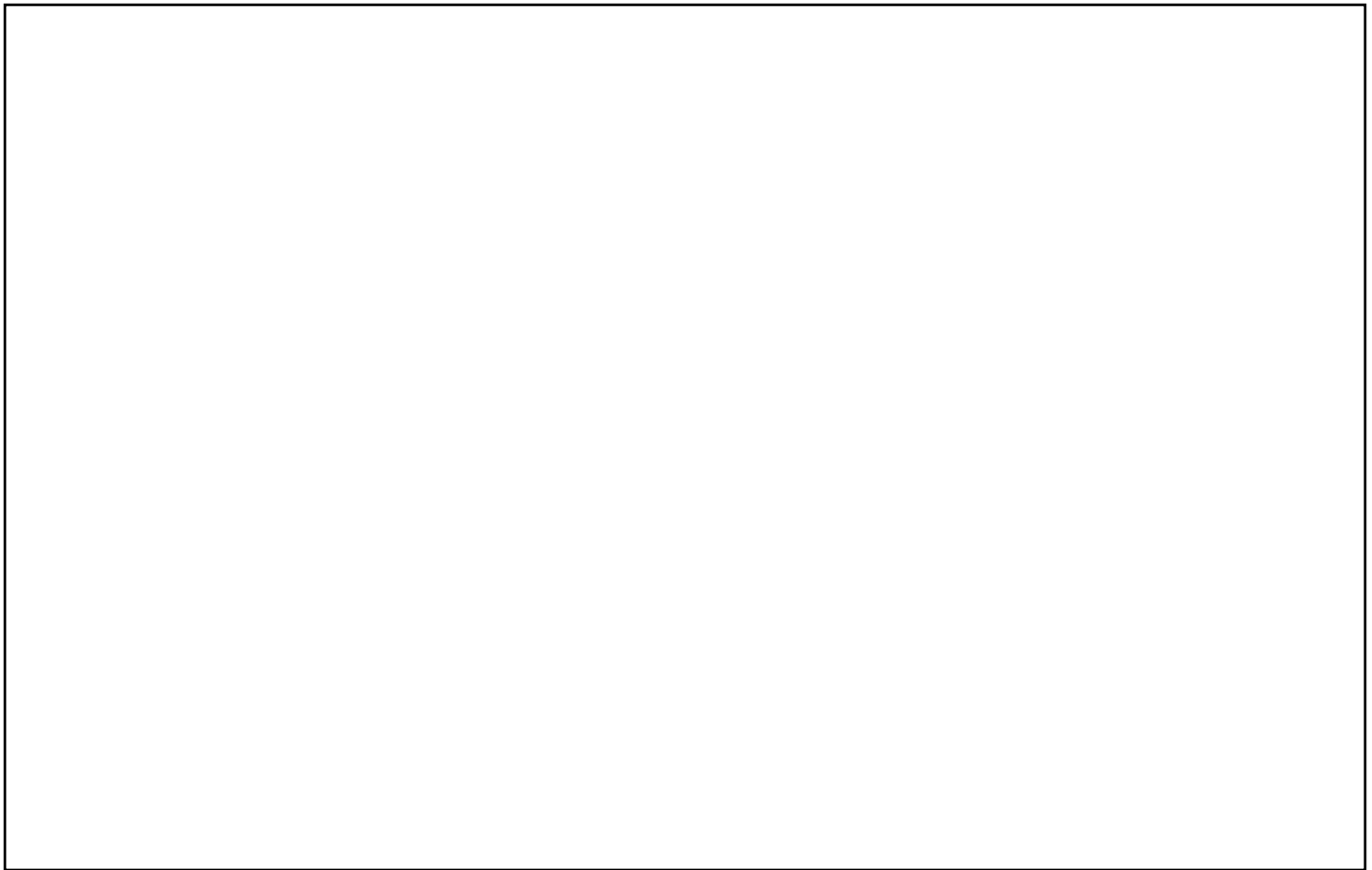

Sketch Plan Example

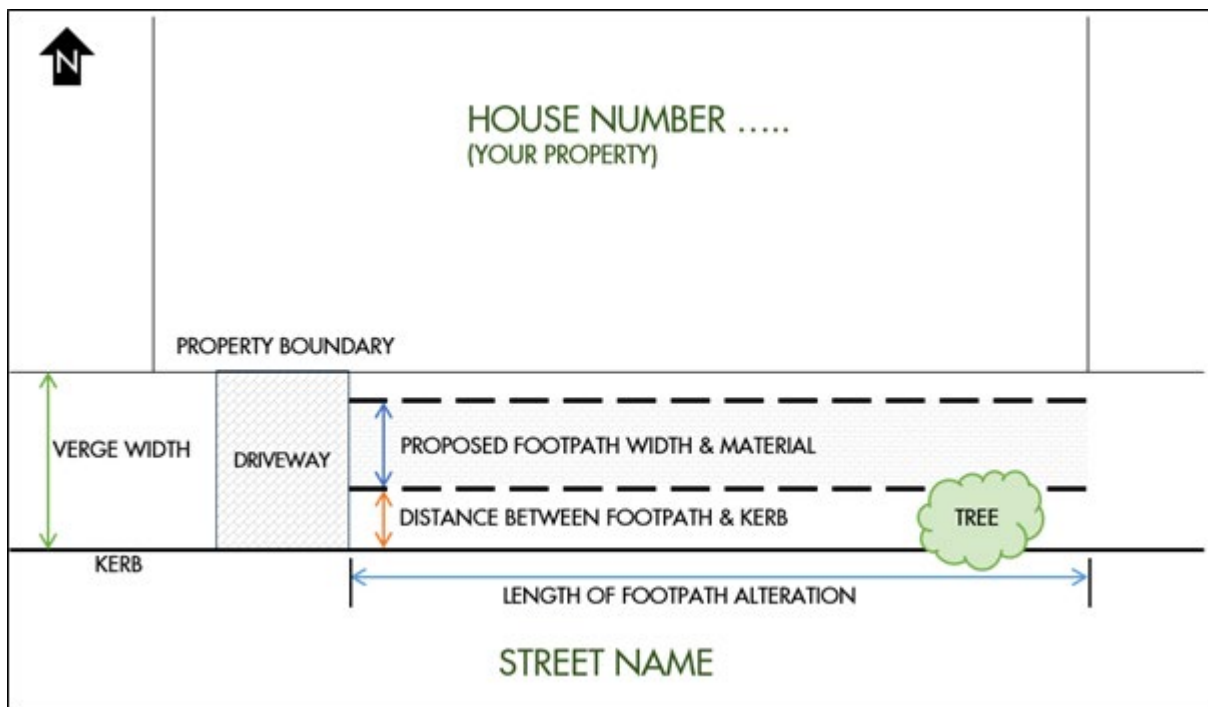

APPLICANT'S DECLARATION

- I, the Applicant, request approval for works in accordance with the details above, the diagram/s attached, and Council's conditions as contained therein.
- I, the Applicant, understand that in accordance with Local Government Act 1999 Section 218, if the works are not constructed in accordance with the approved permit issued by Council; and, rectification work specified by Council is not carried out by the property owner within a reasonable amount of time, Council is able to engage a contractor to carry out the work specified by Council and recover the cost of the work from the property owner.
- I, the Applicant have submitted the contractor's public liability insurance Certificate of Currency in the sum of not less than TWENTY MILLION DOLLARS (\$20,000,000) with this application.

Applicant's Signature: _____ **Date:** _____

**APPLICANT TO
RETAIN THE
FOLLOWING PAGES**

APPENDIX A – CONDITIONS FOR FOOTPATH ALTERATIONS

Footpath Specifications

- The maximum crossfall grade of a footpath is 2.5% (1 in 40) unless approval is provided by Council's officer. A minimum footpath width of 1.5 metres must be provided for pedestrian traffic in accordance with AS1742.3 (Australian Standard Manual of Uniform Traffic Control Devices, Part 3: Traffic Control Devices for Works on Roads) unless approval is provided by Council's officer.
- The backfill must be compacted in layers no thicker than 200mm at 98% density. A top layer of 100mm of quarry sand or quarry rubble is to be compacted to 98% density to the underside of the footpath material.
- Ensure that the proposed does not cause interference to or cause loss of view to pedestrians or motorists entering streets from private property or adjoining streets and intersections.

Footpath Material

Plain Concrete footpath:

- Trench edges must be saw cut to a straight, clean edge. The concrete must be a minimum of 75mm thickness and 20 MPa strength; suitably compacted, finished and matched to the existing surface. The finished surface shall be smooth, level and flush with adjoining surfaces.

Paving bricks or blocks footpath:

- Paving bricks or blocks thickness must be 60mm thick for footpaths. The trench edges must not be cut to a straight line where bricks or blocks need to be interlocked together after construction. The finished surface shall be smooth, level and flush with adjoining surfaces.

Asphalt footpath:

- A minimum of 30mm compacted thickness layer formed from hot mix asphalt laid at temperature within 4 °C of supply temperature. The trench edges must be cut to a straight line. The finished surface shall be smooth, level and flush with adjoining surfaces.

APPENDIX B – GENERAL CONDITIONS

The following conditions are applicable when seeking authorisation in accordance with Section 221 of the Local Government Act 1999 and shall apply in all circumstances.

The issuing of this Authorisation is subject to:

- a. The Applicant agreeing to the General Conditions of Authorisation as contained herein.
- b. The Applicant agreeing to any/all Special Conditions and Specifications that the Council may determine and attach to this Authorisation.
- c. The Applicant advising Council on commencement and completion of any works.

Standards of Care

1. For the term of the Authorisation, to comply with all applicable industry standards, health or safety standards, current standards of Standards Australia or any applicable Code of Practice.
2. To ensure that all works carried out are undertaken to the highest standard and are carried out promptly and with all due care, skill, and diligence.
3. To ensure that any alteration to the road does not interfere with or cause damage to or in any way affect the property of any other person (including Council property).
4. To comply with any direction given by any authority, statutory authority, or Council to remove, maintain or otherwise modify the alteration to the road under this Authorisation.
5. Footpath and service connections must be made safe at all times until all works are completed and accepted by the Council. If the site is unsafe or pose a potential safety hazard, Council will immediately make safe and recover costs from the applicant.

APPENDIX B – GENERAL CONDITIONS

Site Control

6. Underground services must be located prior to commencing excavations. The essential first step is contacting Before You Dig Australia at www.byda.com.au. Damage to public utilities and infrastructure shall be reported to the relevant service authority and will be the responsibility of the property owner.
7. When street trees are present, the contractor shall at all times ensure that any damage to the tree and root system is minimised and seek Council advice prior to undertaking excavation works around any street trees. Existing street trees shall not have their branches cut, damaged or removed without seeking permission from Council.
8. No street furniture (e.g. street signs, signs, power poles, Telstra services, stormwater pits etc.) may be removed or adjusted for any works except within the approval of a Council delegated officer or relevant authority.
9. No material may be stockpiled on the road or footpath at any time. The adjoining road and footpath must be cleared of all rubbish, spillage, excess fill or material and framework as it accumulates.
10. During the work, the site must be kept safe at all times, this may require protected by appropriate safety barriers in accordance with AS1742.3. The work site area shall be kept safe for pedestrians and road users at all times and minimise the restriction of pedestrian and vehicular traffic.
11. A Traffic Management Plan must accompany this application if traffic flow or pedestrian movements will be interrupted.
12. Any on road traffic management must be conducted in accordance with AS 1742.3 (Australian Standard Manual of Uniform Traffic Control Devices, Part 3: Traffic Control Devices for Works on Roads).
13. The works must not restrict access to parked vehicles. Parked vehicles must have access to be able to open passenger side doors.
14. If the condition of a Council asset is altered in any other way than what is outlined on this form, Council need to be notified.
15. Any residents or businesses impacted by works must be advised in writing as soon as possible prior to the commencement of works.

Reinstatement

16. All reinstatement and infrastructure work will remain the responsibility of the property owner and must be completed in a tradesman like manner. The adjoining footpath, road and all other council infrastructure must be reinstated to its original state following the works and be free of obstructions and trip hazards.
17. Every attempt must be made to complete the work as quickly as possible; and, any trenching must be fully reinstated within 7 days of construction.
18. Any trenched area needs to be backfilled with quarry sand or quarry rubble and properly compacted prior to replacement with the same material. Verge must be backfilled with soil or dolomite; not rock, mud or rubble.
19. Any damage to the footpath, verge, kerb or road during works or temporary storage is the responsibility of the owner and must be made good at their cost.

APPENDIX B – GENERAL CONDITIONS

Fixtures

20. All fixtures and equipment erected or installed in, on, across, under or over the road under the Authorisation remain the property of the Applicant pursuant to section 209 of the Local Government Act, 1999.
21. For the term of the Authorisation, to maintain all fixtures and equipment erected or installed, or vegetation planted, in good and safe condition and to recognised standards. Surrounding infrastructure such as footpath, verge, kerbing that may get damaged when completing the work or as a result from the private works must be maintained and repaired.

Indemnities

22. To indemnify the Council, its employees and/or agents against all actions, costs, claims, and demands for injury, loss or damage arising out of any negligent act or omission of the Applicant in relation to any activities under the Authorisation or arising out of breach of any condition attaching to the Authorisation.
23. The Applicant acknowledges that the Council is not liable for any injury, damage or loss resulting from the granting of this permit; and, the Applicant indemnifies and holds harmless the Council in respect of any claim that may arise from such injury, damage or loss.
24. The Applicant accepts responsibility for any damage caused to the road or footpath surface, or any other damage of public property, as the result of these works on a public road; and, understands that Council may complete any repairs necessary and recover the costs from the Applicant, in accordance with the provisions of the Local Government Act 1999 Section 233.

Termination

25. Subject to section 225 of the Act, the Council may cancel the Authorisation for breach of a condition.
26. At the expiration or earlier termination of this Authorisation to remove, if so, directed by the Council, any structure or object erected or installed on the road under the Authorisation and to reinstate the road to the satisfaction of the Council.

About the Authorisation

27. For the term of the Authorisation, to take out and keep current a public liability policy of insurance to an appropriate level of cover per claim in respect of any negligent act or omission of the Applicant in relation to any activities under the Authorisation.
28. Must not assign or otherwise transfer this Authorisation without first obtaining the consent of the Council in writing.
29. Undertaking work without a permit under Local Government Act 1999 and the Development Act 1993 may result in the imposition of a fine.
30. The Applicant must submit a copy of their contractor's current public liability insurance policy with this application. The Certificate of Currency must be for not less than TWENTY MILLION DOLLARS (\$20,000,000).
31. This Authorisation does not confer on the Applicant any exclusive right, entitlement or interest in the road and does not derogate from the Council's powers arising under the Local Government Act 1999.

It is an offence to alter a public road without approval from the Council. Maximum Penalty \$5,000 applies in addition to cost of rectification and administrative fees.

CONCRETE FOOTPATH DETAILS

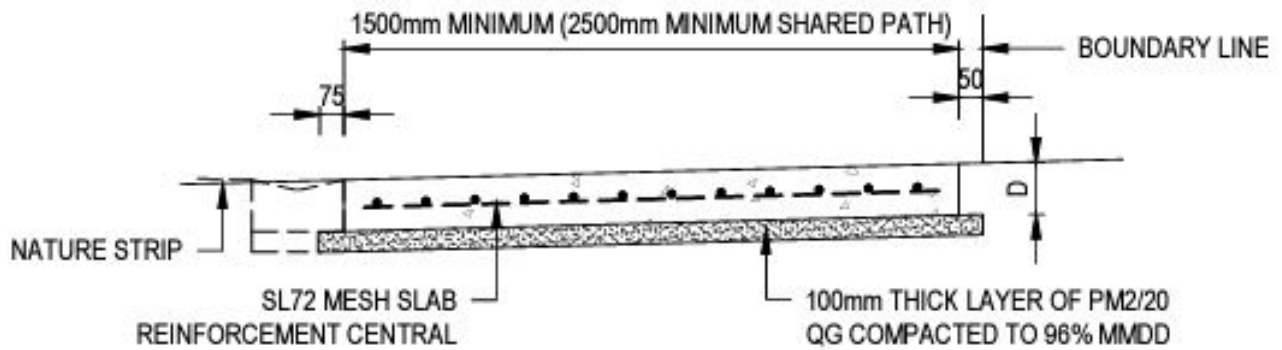

SECTION B-B
TYPICAL 125mm & 150mm FOOTPATH SECTION

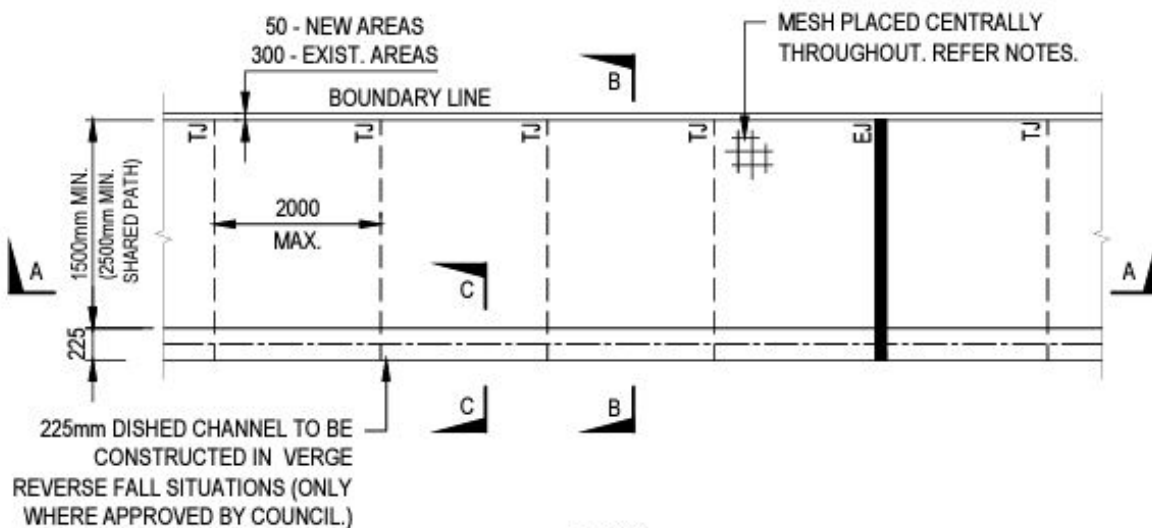

PLAN

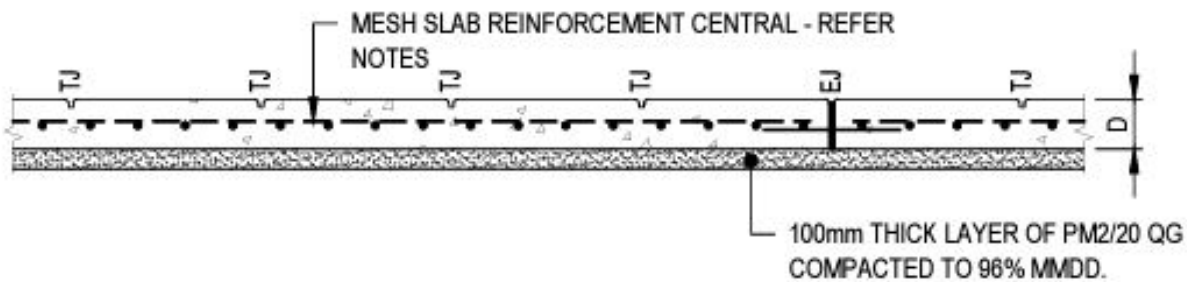

SECTION A-A
TYPICAL 125mm & 150mm FOOTPATH SECTION

APPENDIX C – STANDARD DRAWINGS

BLOCKED PAVED FOOTPATH DETAILS

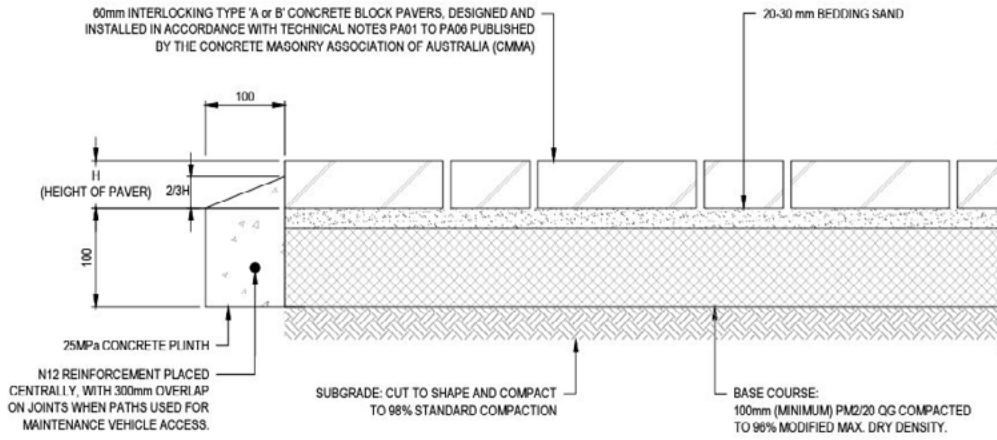

SECTION THROUGH EDGE OF FOOTPATH
SCALE 1:5

TYPICAL ASPHALT FOOTPATH DETAILS

